

This data sheet is to provide a brief description and specification on the truck mount option for the Totalflow NGC 8200 series chromatograph. This mounting option allows the NGC to be used in a portable (that is, transportable) mode when analyzing pipeline quality natural gas to obtain heating value and component composition. The NGC Mobile Mount unit is 12 V DC powered so that it can run on the truck's battery/charging system. It is low pow-

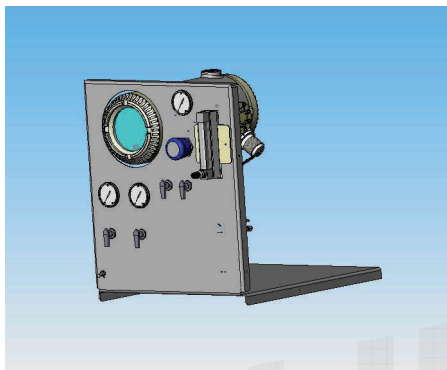

ered enough to leave running continuously, so, when the spot sample needs to be run, the unit is already powered up and stable, hence there is no waiting once at the meter site. From the spot analysis the following are calculated:

- Relative Density
- Heating Value
- VOS
- GPM
- Wobbe index

This data can be used for flow computers, RTU's and SCADA systems for the Energy, AGA3, 7, and 8 calculations at the meter site. This data output can be a CSV file format so that analysis data systems can easily incorporate the information. Analysis done on site is valuable because:

- Transportation of DOT regulated gas cylinders is avoided
- Time and cost of subsequent laboratory analysis
- Problems with sample handling
- Economic solution for gas quality measurement when the gas volumes are too low to justify on-line chromatography

STANDARD FEATURES

- Modular Design:
 - ◇ Modular software – application based plug in software modules
 - ◇ Manifold module (internal tubing now replaced by manifold)
 - ◇ Analysis section contains stream selection solenoids, pressure regulation, 32 bit digital detector electronics and a dual-train chromatograph in a single, replaceable module
 - ◇ 32 bit digital, low-power controlling electronics, using Windows CE® (internal to GC unit)
- Microsoft® Windows® 2000 or XP based man-machine interface software (PCCU 32)
- Lithium battery-backed RAM
- Two remote serial digital communications ports; one local port
- Comprehensive diagnostics and wizards available to users
- Audit-quality historical data; date and time stamped
- Auto-start cycle automatically:
 - ◇ Stabilizes oven temperature
 - ◇ Confirms modules' functions
 - ◇ Sets valve operation times
 - ◇ Locates natural gas components
 - ◇ Sets carrier gas pressures
 - ◇ Gates natural gas components
 - ◇ Validates/calibrates
 - ◇ Returns to pipeline streams
- Operational alarms available with each analysis cycle.
- Detectors - constant temperature, glass encapsulated thermister beads for rugged service and long life. Will not burn out on loss of carrier.
- Dual 10 port valves have no moving metal parts.
- Low utility usage - low-power, low-carrier, no instrument air required
- On demand or scheduled automatic calibration and diagnostics

DESCRIPTION

The truck is moved as close to the sample point as is practical. A flexible sample line is then uncoiled and attached to the probe in the flowing natural gas pipeline. If the dew point of the gas or the weather de-

mands it, this flexible tubing must be heated. A sample of the gas is extracted from the probe in the line, purged through the flexible line and then transported to the analyzer. There it is processed for particle removal and phase integrity, injected onto the chromatographic columns where component separation occurs. These components are then quantified by peak integration and concentration is calculated. The other data of interest is then calculated from these concentrations.

The NGC 8200 analyzes each sample utilizing established chromatographic techniques. The resulting information consists of mole percent values for the following:

Air (Contains N2, CO and O2)
 C1 CO2 C2 C3 IC4 NC4
 NeoC5 IC5 NC5 C6+

The NGC 8206 measures a C6+ peak. Other NGC 8200 series units will do further analysis. These are currently in development. Users may input the results of a comprehensive lab analysis that reflects the split or ratio of C6 through C10 components. This ratio can be used in subsequent analyses and energy calculations.

Calculated values include:

- Relative Density (Specific Gravity)
- Btu/CV (Heating) Value
- GPM (gallons of liquid per thousand Cubic Feet)
- Wobbe Index

HISTORICAL DATA

The NGC 8206 is designed to retain historical data. This data can be used for custody transfer needs, verify transmitter operation over time, and provide a limited data backup for communication link reliability. In addition, various CSV file outputs are available to download the analysis data into spreadsheet based company specific data sheets.

The default* memory configuration provides the most recent 480 analysis cycles containing:

- Normalized components
- Un-normalized components
- Ideal Btu/CV
- Real Btu (wet and dry) / CV (superior and inferior)
- Relative Density (Specific Gravity)

- Density
- GPM
- Wobbe index
- Alarms

Stream averages for the (default¹) 840 last hours, 35 last days and the most recent last month analyses.

Operational Parameters for the (default¹) last 480 cycles (Diagnostics Report):

- Selected peak times
- Selected peak areas
- Ideal Btu/CV
- Carrier regulator pressure
- Oven temperature
- Ambient temperature
- Sample pressure
- Detector noise values
- Detector balance values

Audit logs (Default*)

- Last 480 alarms
- Last 480 events

Data retained by the NGC 8206 can be collected via a remote communication link or by the laptop PC local operator interface PCCU 32.

EQUIPMENT

The equipment used for this analysis consists of the standard NGC 8206 mounted on a powder-coated gas handling panel. This panel is then shock mounted with geosies grade isolators to provide a very durable installation for the back of a pick-up, van or suburban. It is recommended that the unit be left in an operational mode while transporting.

All the valves, gauges, inlet ports, and PCCU32 (the laptop driven man-machine interface) connectors are bulkhead mounted on a vertical gas handling panel to provide the technician with ready access. That is, it is designed for operation from the tailgate of a pick-up truck.

¹ The default memory configuration will provide for the data storage above. User may reallocate memory

SPECIFICATIONS

- Designed for Pipeline-Quality Natural Gas. 800 to 1500 Btu per standard cubic foot (29.8 to 55.9 megajoules/meter³)¹ with less than 100 PPM H₂S
- Calculations Per: GPA 2172-96 (Z by AGA 8 or single virial summation) and 2145-03, ISO 6976-95; in the future: ASTM D 3588, GOST or ISO mass
- Carrier Gas: Helium (consumption rate <20 ml/minute during analysis cycle)
- Analysis Time: Approximately five (5) minutes; cycles may be scheduled by user
- Repeatability: ±0.125 Btu @ 1,000 Btu (±0.0125%) at ambient; and ±0.25 Btu @ 1,000 Btu (±0.025%) over temperature range of 0 to 131°F (-18 to 55°C)
- Temperature Range (Reliable Operation): -40 to 131°F (-40 to 55°C)²
- Temperature Range (Storage): -22°F to +140°F (-30°C to 60°C)
- Supply Voltage: 10.5 to 16 volts DC (Future applications 16 to 28 VDC as an option)
- Power Consumption (Normal operation @ 0°F -18°C) = 7 Watts;
- Start up: less than 3 amps (45 Watts @ 15 VDC)
- Meet or exceeds GPA 2261-99 for linearity
- Four stream capability. Manual calibration required with 4 sample streams.
- Single auto calibration stream and 3 sample streams, or 2 auto calibration streams and 2 sample streams.
- Certifications:
 - ◊ NEC & CEC Class I, Div. 1, Groups C and D, T6
 - ◊ CFR 47, Part 15
 - ◊ **CE**:
 - ATEX  II 2G : Ex d, IIB+H₂ T6; Class 1, Zone 1
 - EMC - EMI/RFI:
 - EN 55022, EN 61000-6-1, EN 61000-4-2, 4-3, 4-4, 4-6, 4-8
 - CISPR 22-2004
- Communications supported:
 - ◊ RS-232; RS-422; or RS-485 (maximum of any two), software selectable, and one dedicated RS-232 Man-Machine Interface
 - ◊ Optional USB hub (host and client) and Ethernet
- Protocols Supported:
 - ◊ Totalflow Remote / Local MMI

- ◊ Totalflow / TCP
- ◊ Modbus / TCP Server
- ◊ Modbus / TCP Client
- ◊ Modbus ASCII or RTU (Modicon, WordSwap, or Danalyzer)
- Dimensions: ?
- Weight: Approximately 45 lb.
- Shipping Weight: Approximately 55 lb. (24.95 Kg)
- Weatherproof Construction: Designed to meet NEMA-4X Aluminum alloy with white polyester powder coating or aluminum lacquer

AVAILABLE OPTIONS

- 120/240 VAC / 24 VDC to 12 VDC power supply
- Two Options of Modular Sample System for Non-pipeline quality natural gas and Sample transport lag-time needs: Type 3 and Type 4 w/ liquid shut-off
- Temperature Compensation Probes:
 - ◊ Fixed
 - ◊ Retractable
- Regulators, carrier and calibration blend
- Start up/calibration/validation gas sample (±2% Cal Blend)
- Export crating
- Tool kit
- Various maintenance kits
- On board digital 1/4 VGA display with multiple screen access
- USB (Host and Client) and Ethernet ports
- Calculation packages (eg, V.O.S.)
- SD memory cards
- Feed-Through heater
- C₇+, C₉+ analysis (future)

² The NGC will operate reliably down to -40°F (-40°C) if the proper cold weather accessories are used.

PRELIMINARY

Power and Productivity
for a Better World. TM

www.abb.com/totalflow
www.abb.us
www.abb.com



ABB Inc.
Totalflow Products
7051 Industrial Blvd.
Bartlesville, OK 74006
Tel: (918) 338-4888
Fax: (918) 338-4699
(800) 442-3097

ABB Inc.
Totalflow Products
433 Northpark Central Dr., Ste. 100
Houston, TX 77073
Tel: (281) 869-5212
Fax: (281) 869-5203
(800) 442-3097

For more information,
please contact your
local ABB Totalflow
representative or visit
our website.