

Canalta

Flow Measurement

A Canalta Controls Company

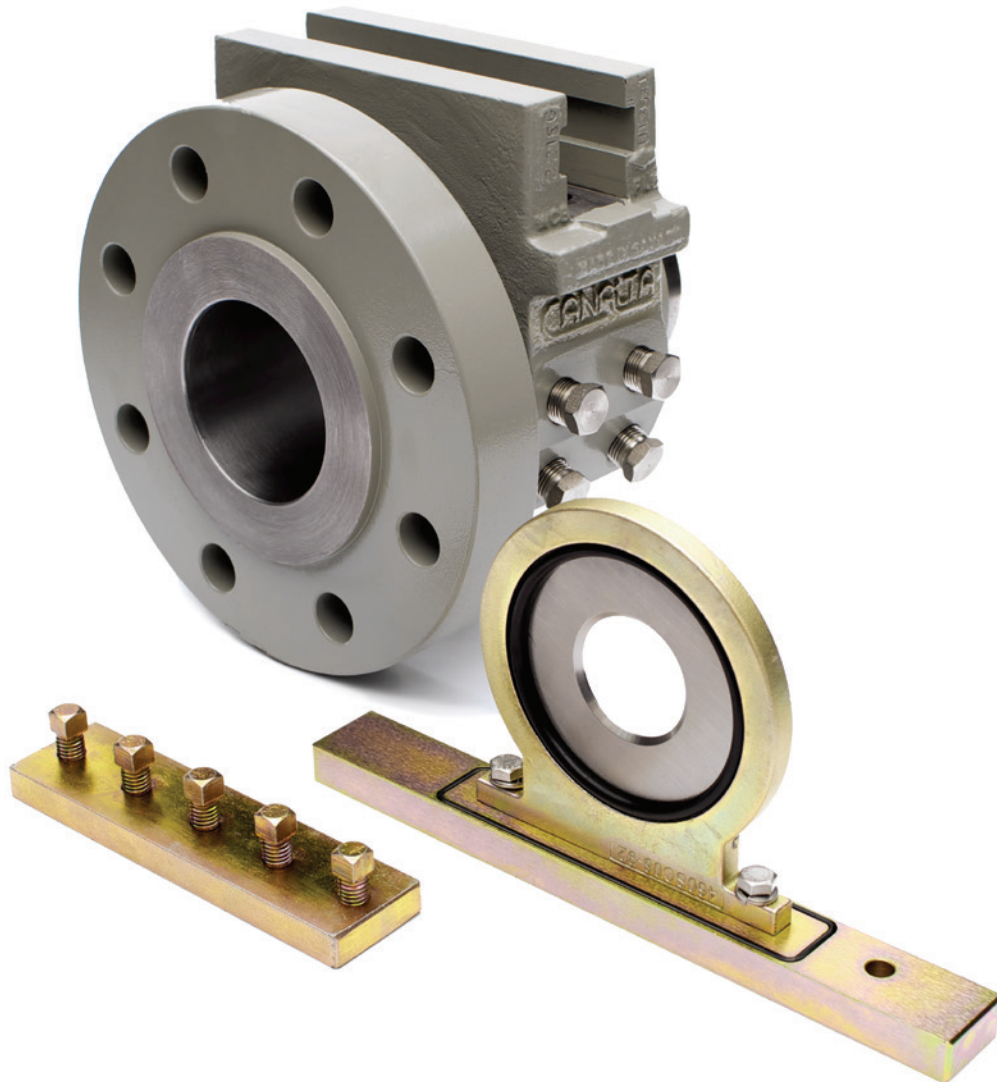

The Canalta Single Chamber Orifice Fitting

Exceptional Value means adding to your *Bottom Line*

without sacrificing *Quality, Service* or *Performance*

Call Us Toll Free: 1-855-CANALTA

An ISO 9001:2008 registered company

Phone: 403.342.4494

Email: sales@canaltaflow.com

www.canaltaflow.com

The **Canalta Single Chamber Orifice Fitting** is a high quality, high accuracy orifice fitting manufactured in a wide selection of sizes and materials. These units are built to meet or exceed ASME and ANSI specifications, as well as to comply with the requirements of the latest editions of AGA-3 / API-14.3 and ISO-5167. Whatever the application, your process will benefit from Canalta's proven reliability and you can improve your bottom line without sacrificing quality, service or performance.

All Single Chamber Orifice Fittings come standard with **HNBR O-ring seals** on the seal bar. This feature provides you with superior sealing capability while eliminating nuisance gasket maintenance and clamping bar screw breakage. The O-rings incorporated are standard shelf sizes and can be supplied in a wide variety of compositions. Gaskets are also available and can be used when preferred or required.

Delivering superior orifice fittings and exceptional value has been our core business for over fifteen years.

*FOR OVER FIFTEEN YEARS
WE'VE BEEN ON THE FRONT LINE*

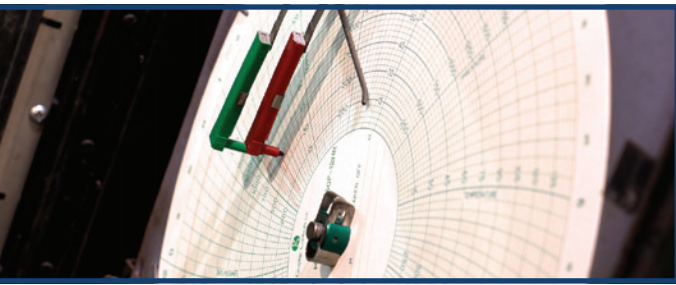
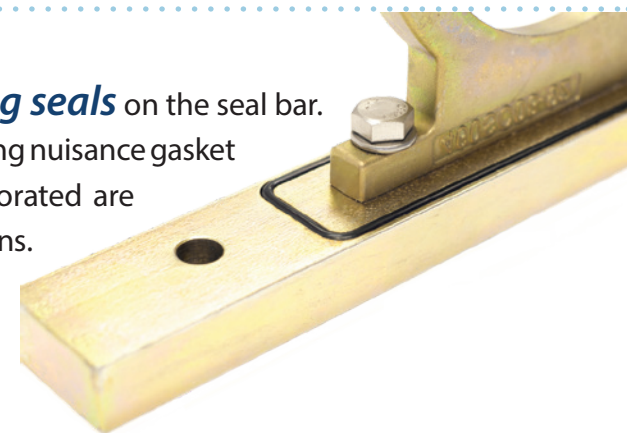
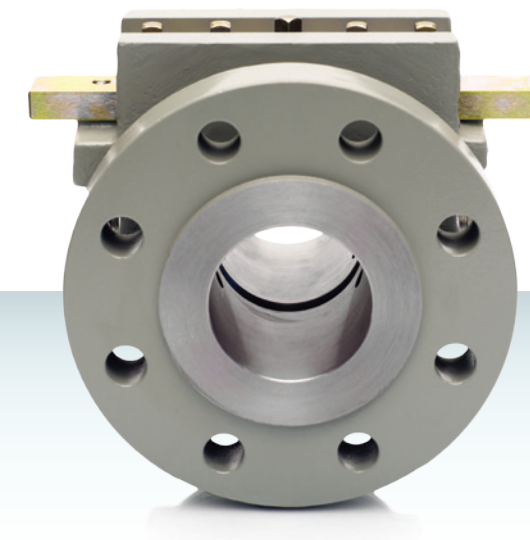
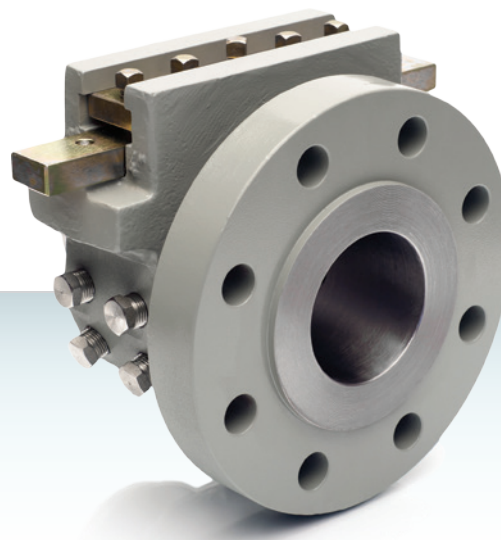
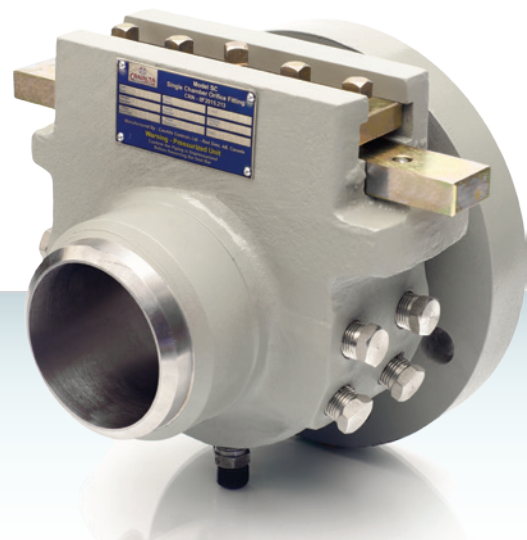

Our comprehensive **Quality Management System** includes full function, hydrostatic and pneumatic pressure testing to prevent defective orifice fittings from reaching service. Standard testing comes at no extra charge and includes verifiable pressurization to 150% of working pressure. Additional inspections, such as radiography, ultra sonic and liquid dye penetration, are also available.



Our unit-specific **Documentation** packages include hydrostatic, seal and function test results as well as material test reports. An AGA 2000 Inspection Report is submitted with every fitting and includes bore tolerance and roughness tests, orifice eccentricity, seal protrusion, plate sealing tests and other details critical to your process integrity.



Each Canalta Single Chamber Orifice Fitting receives a standard coating that includes a non-lift oxide primer and fast-drying enamel finish in Canalta Grey. Custom coatings for special environments - maritime, humid, high temperature and others - custom colours and primer only applications are also available.

Single Chamber Orifice Fitting models 8" and larger incorporate a rack and pinion gear system to manage the sizeable weight of large orifice plates and carriers. With this system, plate changing remains quick and easy.

These models also feature fully accessible and adjustable eccentricity of the orifice plate from the exterior of the fitting. Tamper-proof sealing is done on request.

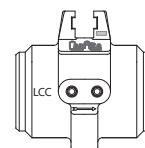
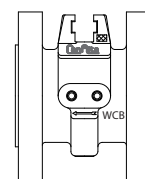
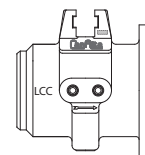
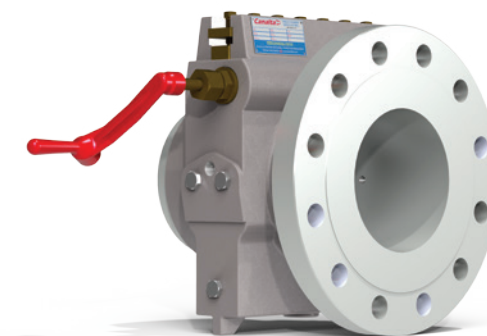

Canalta Single Chamber Orifice Fitting bodies are available in a number of standard and custom end configurations. Some of our most popular arrangements include

- Flangeneck (welding neck upstream, raised face / RTJ flange downstream)
- Flange X Flange (raised face / RTJ)
- Weldneck both ends

Single Chamber Orifice Fitting Bodies are also available with an extra set of tele-metering tap holes on each side as an option.

METER RUNS

All Canalta Single Chamber Orifice Fittings can be supplied with complete custom-designed *Meter Runs* and *Flow Conditioning Solutions* that meet your exact specification or performance needs.

Whether the size is 2" or 30", high or low pressure, wet, dry or corrosive service, we can put together a custom meter run package that meets your specification or performance needs and perfectly matches your Canalta Orifice Fitting.

You trust Canalta at the orifice plate. When accuracy counts, trust Canalta up and downstream, too.

We've been working to AGA-3 / API 14.3 and ISO 5167 specifications for over fifteen years. Skilled technicians, engineers and inspectors work together to manufacture first-rate meter tubes out of pipe carefully selected and prepared with the appropriate surface requirements, roundness and I.D. tolerances. Hydrostatic test results are included as a standard. PWHT stress relief, ultra-sonic and liquid dye penetration test results are available on request. Our rigorous inspection regime and comprehensive documentation mean you can be sure your meter run is reliable, exceptionally accurate and ready for service.

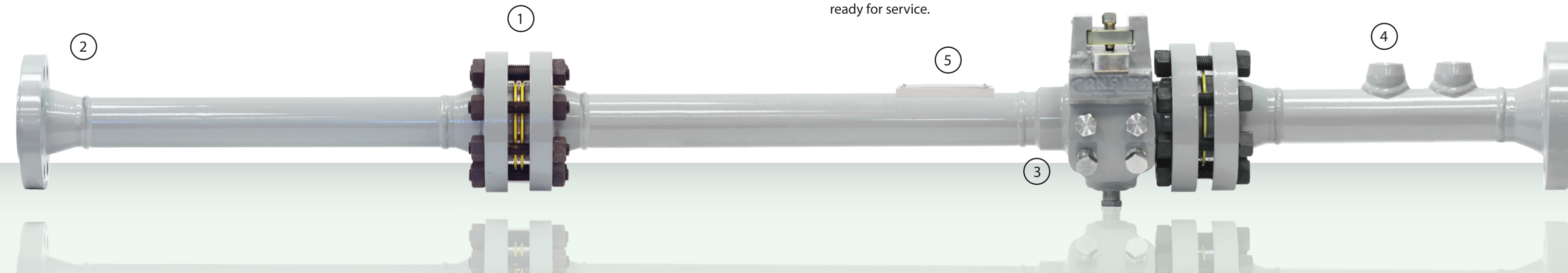

1 FLOW CONDITIONING ACCESSORIES

The goal of meter run design is to account for swirl and turbulence. Suitable for a wide range of flow measurement methods and equipment, Canalta's Contour™ lineup of Flow Conditioners, Flow Conditioner Housings and Straightening Vanes will help you develop the flow profile you need to achieve maximum performance and accuracy in the field.

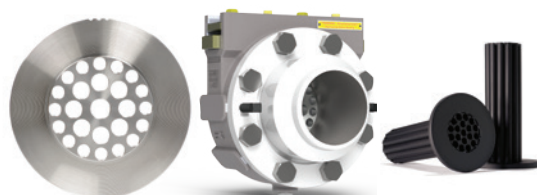

2 END CONNECTION OPTIONS

Canalta Meter Runs can be fabricated with a variety of standard tube ends. All inner surface welds are precision ground and inspected to meet exacting I.D. surface and roundness tolerances. Per your requirements, two and three-piece meter runs can have dissimilar end types up and downstream of the orifice fitting.

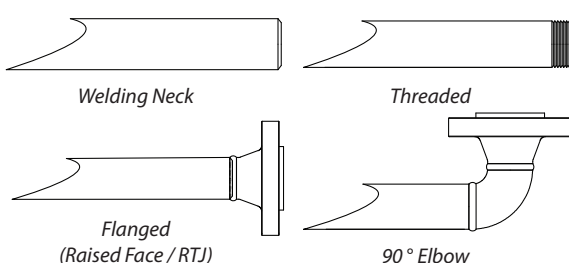

3 WELDING SPECIFICATION

Each Canalta Meter Run is professionally fabricated by our team of certified "B" Pressure Welders and experienced pipe finishers to meet and exceed the stringent specifications of AGA / API / ISO. Our welding procedures are registered with the Alberta Boiler and Safety Association (ABSA) and are in accordance with the applicable ASME Boiler and Pressure Vessel Codes. Canalta will ensure that all of your NDT and stress relieving requirements are met with full documentation.

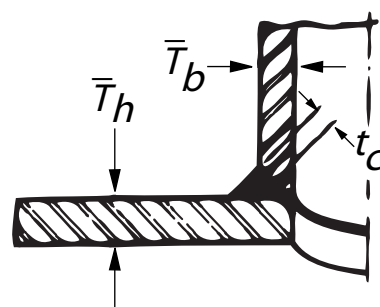

4 BRANCH CONNECTION OPTIONS

Industry standard offerings provide one 1" and one 3/4" branch connection on the downstream spool. Our custom meter tube design capability allows us to fabricate nearly any combination of weldolets, sockolets, flanged outlets, threaded outlets and latrolets in any orientation.

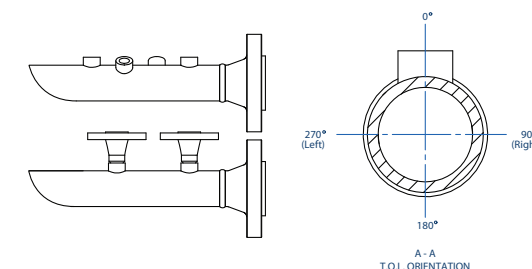

5 METER RUN SPECIFICATION PLATE

All Canalta Meter Runs include a specification plate mounted immediately upstream of the orifice fitting. These spec plates detail pipe schedule, pressure rating, maximum beta, maximum orifice and other information essential to proper operation.

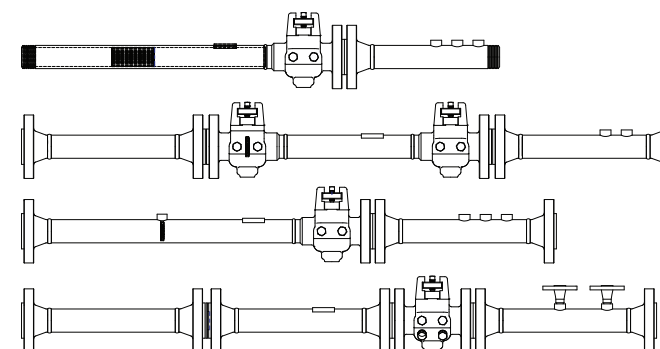

With literally endless configurations possible, Canalta will custom design and fabricate your meter run for any application.

**ACCURACY, RELIABILITY,
PERFORMANCE.**

FLOW CONDITIONING ACCESSORIES

Contour™
Flow Conditioning Solutions
by **Canalta**

Flow profile is critical to differential pressure measurement accuracy. Swirl effects, turbulence and pulsation all degrade the accuracy of your meter and potentially reduce profits. You can protect your bottom line.

Canalta offers a variety of **OEM Flow Conditioning Elements** to perfectly match all of our Single Chamber Orifice Fitting models. By delivering a fully developed flow profile to your measurement device, regardless of upstream piping, our lineup of Contour™ Flow Conditioners allow you to drastically reduce the amount of straight run upstream piping required. Cost, size and weight are reduced without significant drops in pressure or reliability.

Contour™ K5 Flow Conditioners are designed and manufactured to the exact geometries of the popular K-Lab / Nova design. Years of testing by third parties has made this geometry a veritable industry standard, and Canalta's robust quality control program ensures that our customers receive the best flow conditioners possible.

Canalta also offers the the Contour™ Z Flow Conditioner, featuring the 32-hole Zanker plate geometry, as well as the Contour™ Vane Flow Straightener. All units are available for pipe sizes 2" through 30" in all standard schedules, with custom schedules by special order.



Contour™ Vane Flow Straightener



Contour™ K5 Flow Conditioner

Canalta's **Contour™ FCH Flow Conditioner Housing** brings the ease, safety and practicality of inspecting and changing an orifice plate to the flow conditioner. This long overdue concept allows for regular inspections of the flow conditioner without breaking apart the flow line. The Canalta FCH™ allows the operator to easily perform flow conditioner inspection and maintenance on the same regular schedule as the orifice plate. With this innovative, patented design, you can be sure that your flow profile has not been degraded by damage, blockage or residue accumulation.

All bore surfaces and internal dimensions within the housing are manufactured to strictly comply with the latest editions of AGA-3 and ISO-5167. The Contour FCH is effective for custody transfer applications or any measurement scenario where flow profile and measurement accuracy are critical.

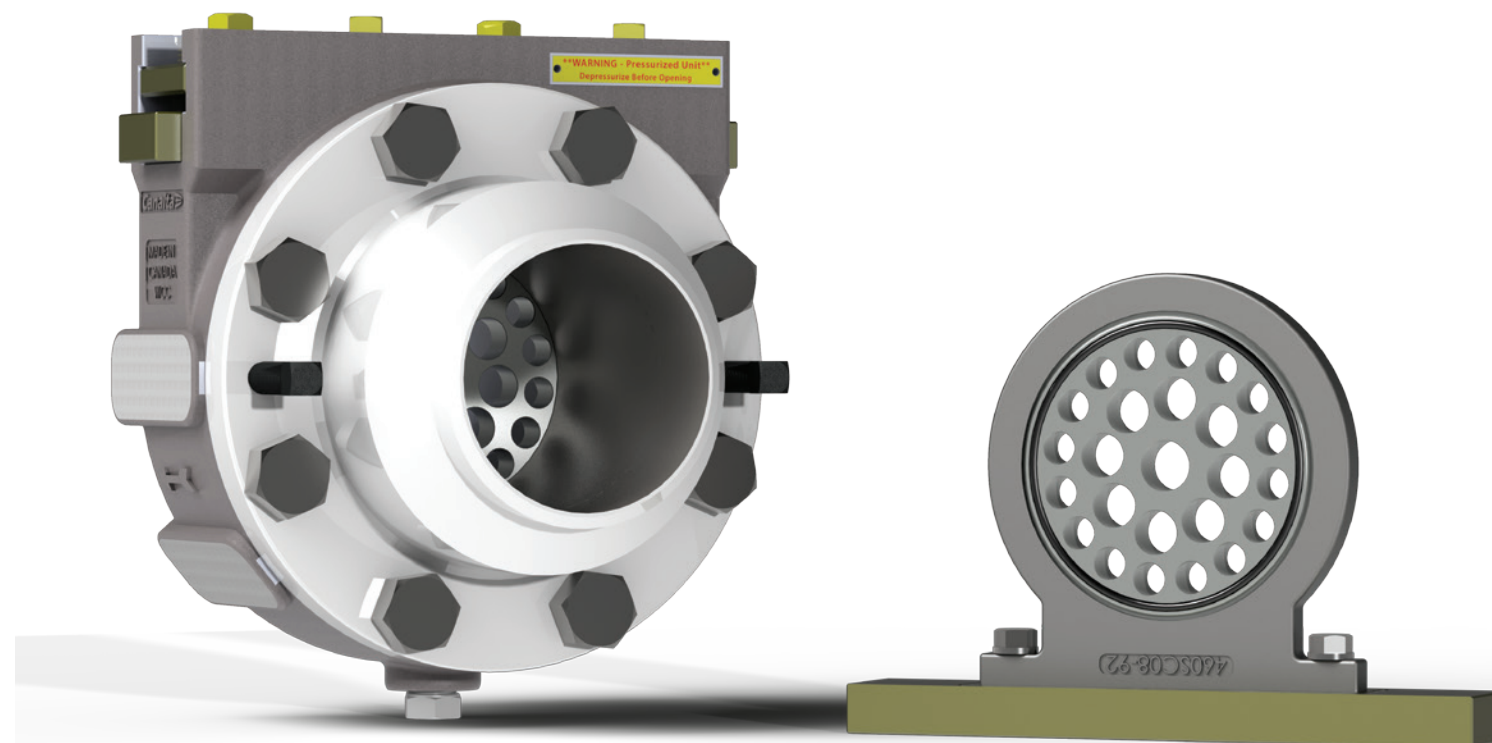

US Pat. 7,806,145



Canalta's Contour FCH utilizes the new Contour K5+ and Z+ Flow Conditioners. These isolating flow conditioners incorporate a non-protruding HNBR seal around the downstream face to prevent bypass leakage and protect the integrity of your flow profile.

CONTACT US TODAY TO FIND OUT MORE

ORIFICE PLATE SEAL OPTIONS & CARRIER ASSEMBLIES

Type "K" Standard 2000 Edition Seal Assembly

This is the standard seal assembly supplied with all orifice fittings from sizes 2" through 8". This unit is used with a .562" seal gap for fittings sized 2" through 6", and with a .688" seal gap for 8" fittings. The single downstream seal function offers superior sealing capability while reducing seal damage during insertion. Plate seal bypass tested down to 1" water column.

The seal assembly is comprised of an elastomer seal and one stainless steel retainer ring. Exact and repeatable concentricity is maintained with the metal to metal contact throughout the entire 360° circumference of the orifice plate to the plate carrier mechanism.

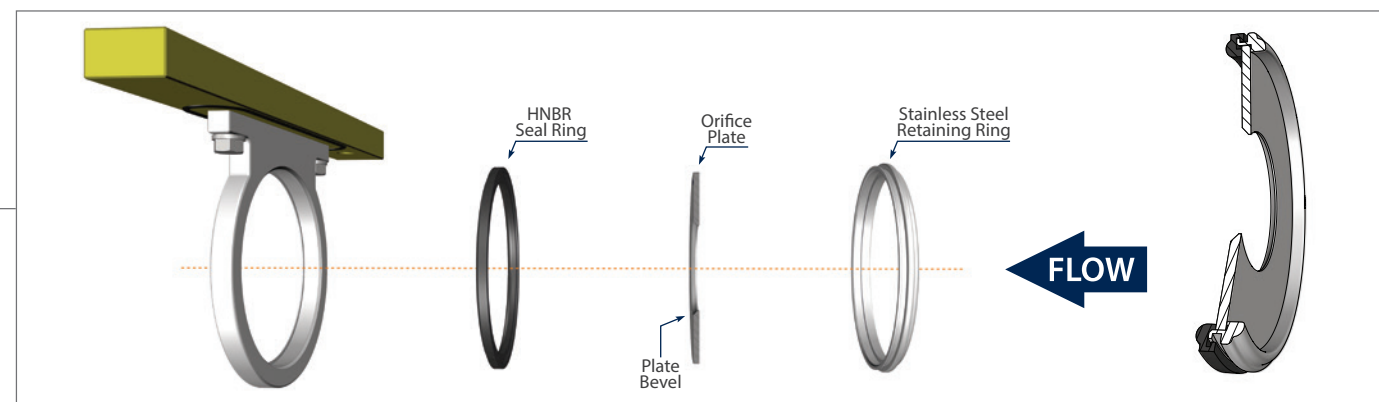

Dual Ring Seal

Canalta's Dual Ring Orifice Plate Seal is an innovative response to ultra-harsh process environments, performance challenges and the need for operating cost improvements. Two rugged 316 SS retaining rings encapsulate the orifice plate, providing bypass protection with two standard sized O-rings. Operators can easily source additional rings for replacement or to match changing service conditions. The unique seal structure provides excellent eccentricity and plate deflection performance.

Available as standard with 80 duro HNBR sealing components, with exotics available by special order. Retaining rings also available in Teflon.

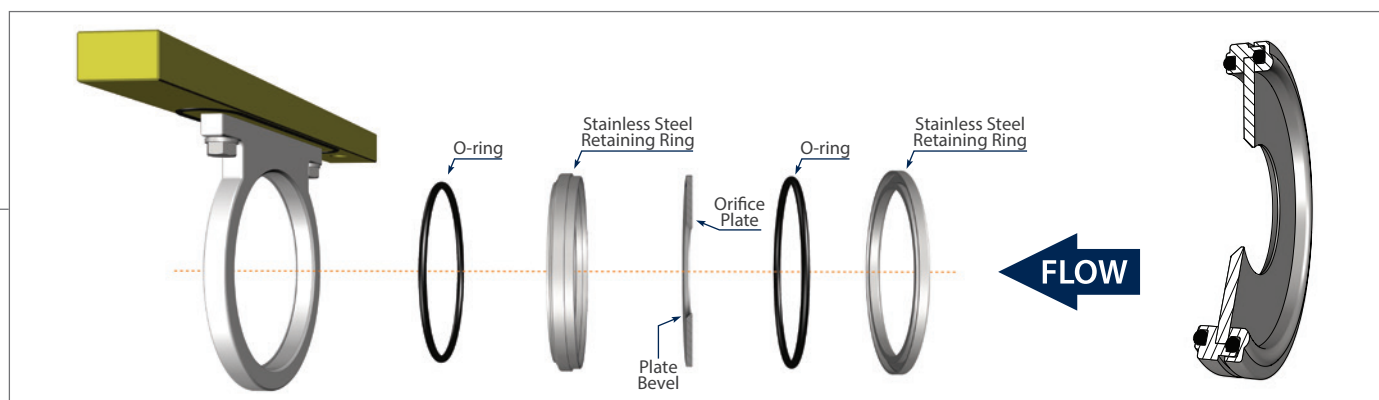
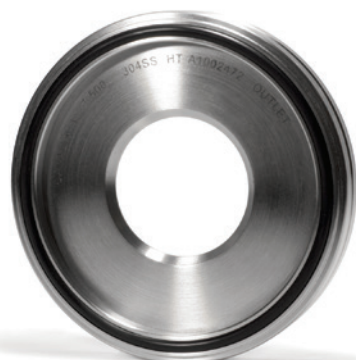

Teflon Snap Seal

The Teflon Snap Seal provides positive plate sealing in the harshest of process environments. The two-piece design snaps over the orifice plate without the use of metal clips or retainers. A specially designed recess absorbs the insertion pressures, minimizing permanent compression and distortion.

The raised section adjacent to the recess creates a positive seal against the orifice plate, preventing bypass leakage. These two unique design features enhance seal performance while extending the life expectancy of the seal assembly.

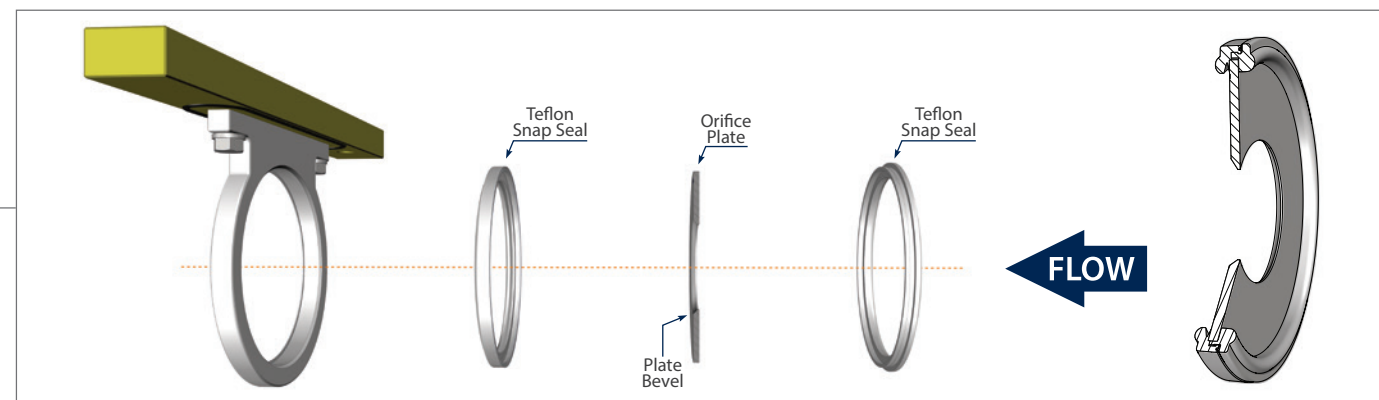
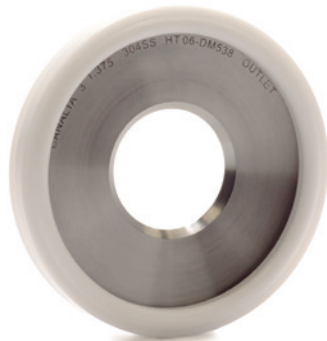

Bonded Seal

This is the standard seal supplied with all Canalta Orifice Fitting model sizes 10" and larger. Designed with a unique "hollow core" recess, this seal has impressive expansion and contraction capabilities when compared to traditional solid rubber seals.

The recess allows the seal to absorb insertion pressures, minimizing tearing, distortion and permanent compression. The 80 duro HNBR seal is adhesively bonded to the orifice plate, creating total and permanent contact between the plate and seal and preventing bypass leakage.

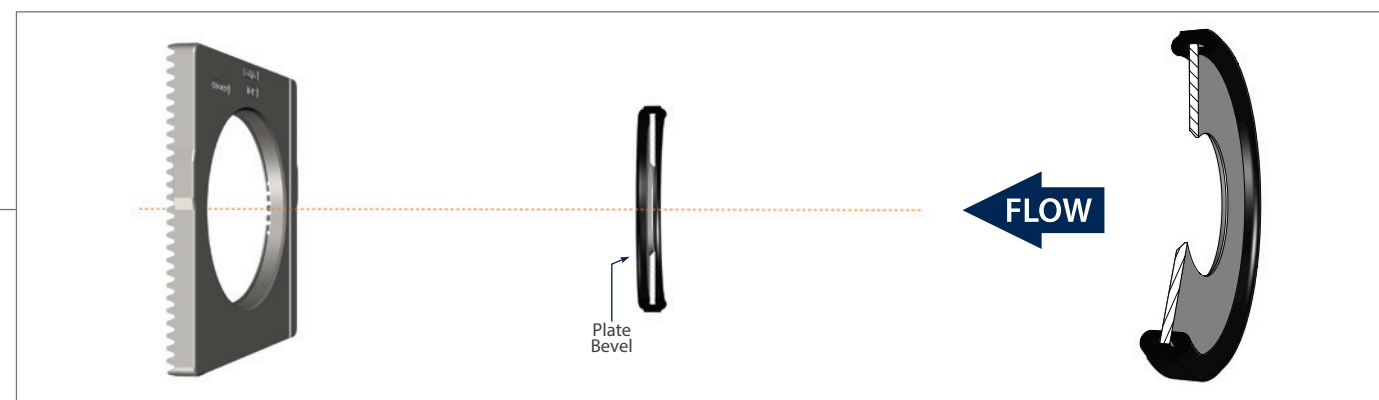
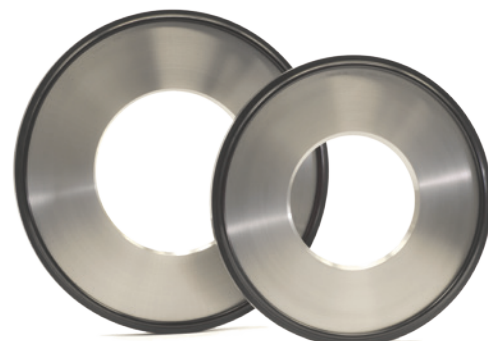

TECHNICAL SPECIFICATIONS

Design	Orifice fittings supplied in Canada are built in accordance with the ABSA Quality Control Program and carry a CRN registration number. Industry Canada Approval Number AF-0014. In compliance with ASME 16.34 and ASME 16.5, ASTM specifications, AGA-3 Latest Edition and ISO-5167.
Body Materials	A216 WCB, A216 WCC, A352 LCC, A358 CF8M, A995 Gr4A, A995 Gr6A, Custom
Internal Parts	AISI 4130 Carbon Steel, 316 or A351 Stainless Steel
Sizes and ANSI Class	2" through 30", 150 through 2500 ANSI raised face flange 600, 900 and 1500 flanges also available in RTJ face flange
U/S D/S Connections	Flangeneck design (weldneck U/S, flange D/S) Flange x Flange Weldneck both ends
Internal Bore Sizes	40, 60, 80, 100, 120, 160 and custom sizes
Sealing Compounds	Seal bar - HNBR O-ring standard, gasket optional Orifice plate - Type "K" 2000 Edition formed HNBR seal on a 316 SS retainer ring Dual Ring HNBR O-rings standard on a 316 SS retainer ring assembly Teflon Snap Seal two-piece virgin Teflon assembly
Line Bore I.D. Tolerance	In conformance with AGA-3 and ISO-5167 Latest Editions
Eccentricity Repeatability	In conformance with AGA-3 and ISO-5167 Latest Editions
Tap Connections	Two 1/2" NPT per side standard, two 1/2" NPT additional per side optional (TT) 2" and 3" fitting sizes center bored to .375" inside diameter 4" and larger sizes center bored to .500" inside diameter Tolerance +/- 1/64"
Orifice Plate Seal Gap	2" through 6" = 0.562", 8" through 14" = 0.688", 16" through 20" = 0.813", 24" through 26" = 0.875"
Operating Shaft Location	Shafts are a feature only on fitting sizes 8" and larger Left hand mount standard on sizes 8" through 16" Dual operation on sizes 20" and larger
Operating Temperature	Standard at -20° to 100° F, optional -40° to 1200° F
Operating Position	Vertical or horizontal

Conformance

All fittings come standard with a documentation package including hydro-test, function test, inner valve seal test, quality control inspection and material test reports. Trace ability is maintained in accordance with the ISO-9001 Quality Control Program. The fittings are manufactured within the guidelines of ASME 16.34 and ASME 16.5. When required, radiography, stress relief, ultra-sonic and liquid dye penetration tests can be performed with the relevant report submitted.

Reporting

An AGA 2000 inspection report is included with the purchase of every fitting. The documented tests include:

- | | | |
|------------------------|---------------------------|---------------------------|
| • I.D. Bore Tolerance | • Instrument Tap Diameter | • Instrument Tap Location |
| • Tap Communication | • Plate Seal Test | • Seal Protrusion |
| • Orifice Eccentricity | • Bore Inside Diameter | • Bore Roughness |



“Our **Quality Control** systems guarantee that your **Canalta Orifice Fittings** are **service ready, reliable and truly accurate.**”

KEY OPERATING PARTS AT A GLANCE

2" - 6" SINGLE CHAMBER MODELS

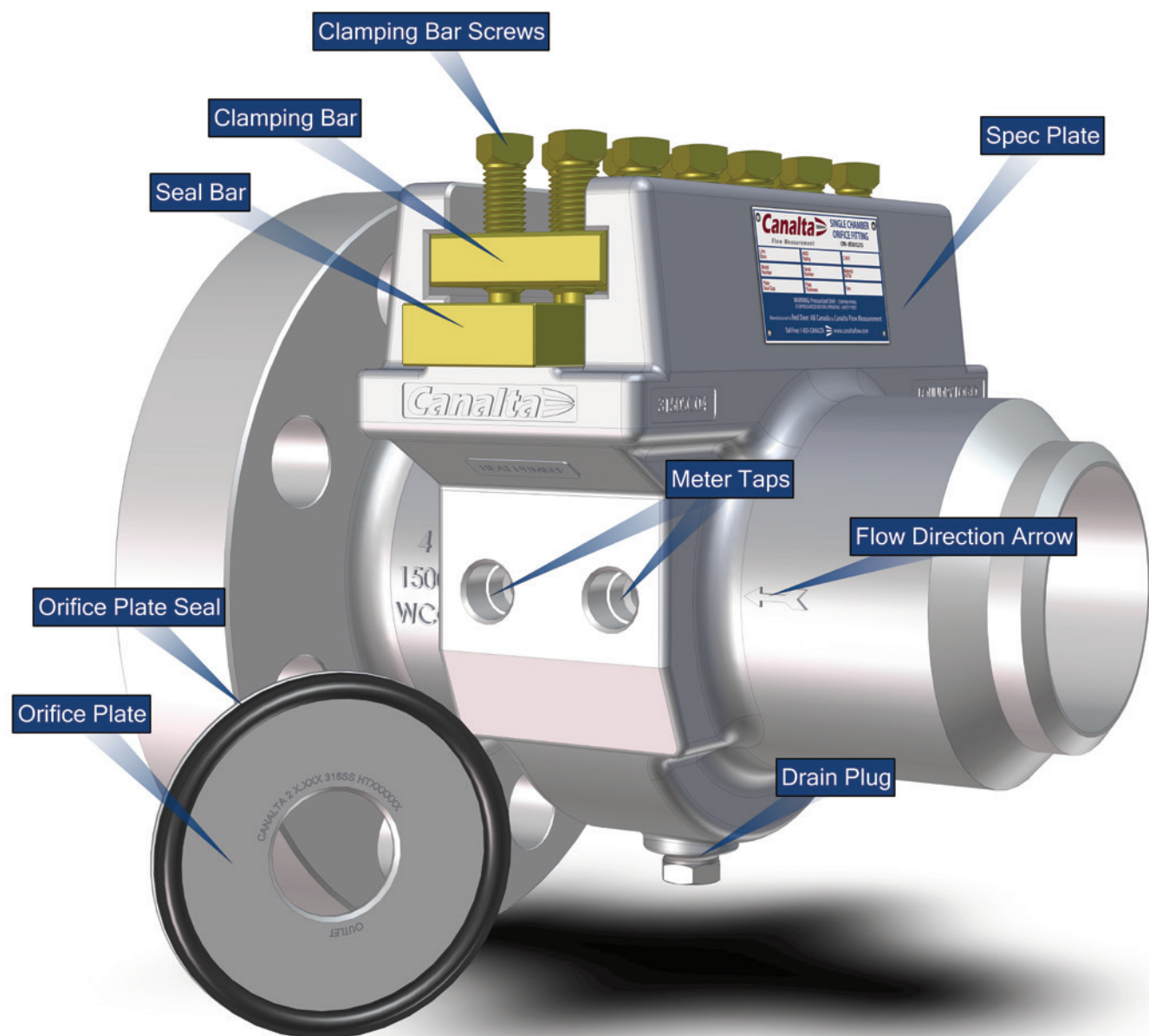

8" - 16" SINGLE CHAMBER MODELS

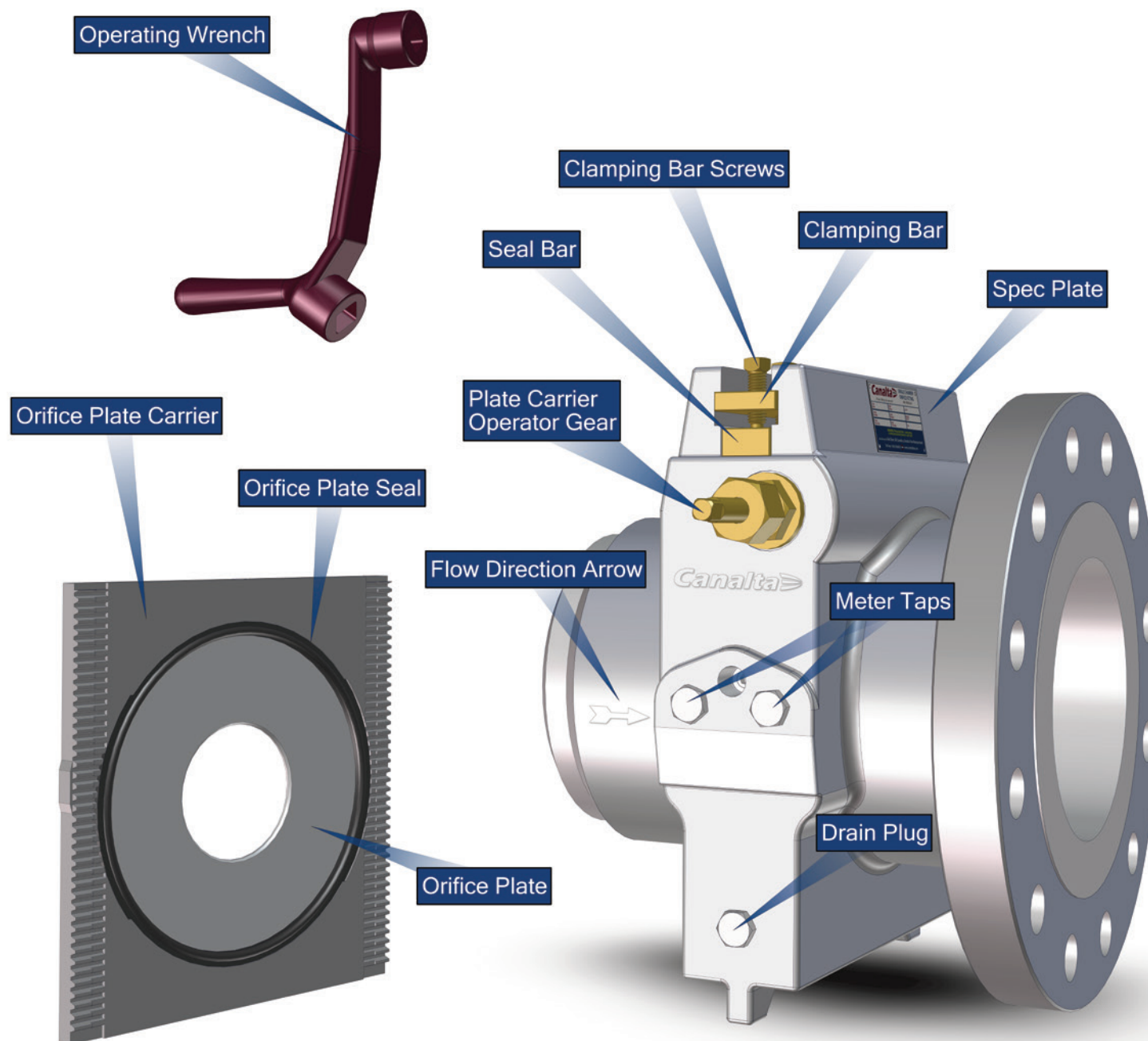

OPERATIONS & MAINTENANCE

2" - 6" SINGLE CHAMBER MODELS

TO REMOVE THE ORIFICE PLATE

- Ensure that the fitting is completely depressurized.
- Loosen the clamping bar screws and remove the clamping bar.
- Remove the plate carrier and seal bar unit.
- Remove the orifice plate and seal assembly from the plate carrier.
- Extract the orifice plate from the seal.

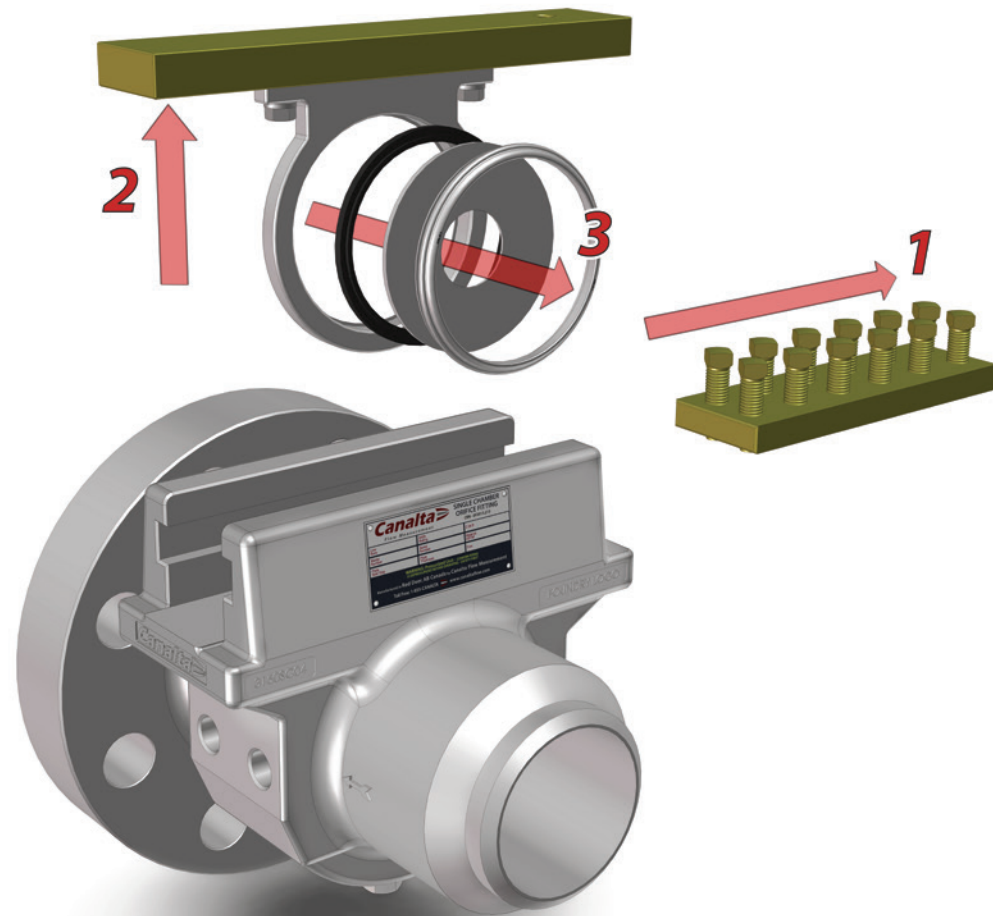

WARNING: The unit may be under extreme high pressure. Failure to depressurize the line before attempting to remove the seal bar may result in bodily harm or death. Follow all instructions carefully.

8" - 16" SINGLE CHAMBER MODELS

TO REMOVE THE ORIFICE PLATE

- Ensure that the fitting is completely depressurized.
- Loosen the clamping bar screws.
- Remove the clamping bar and seal bar.
- Rotate the plate carrier pinion gear to raise the plate carrier assembly.
- Remove the orifice plate and seal assembly from the plate carrier.
- Extract the orifice plate from the seal.

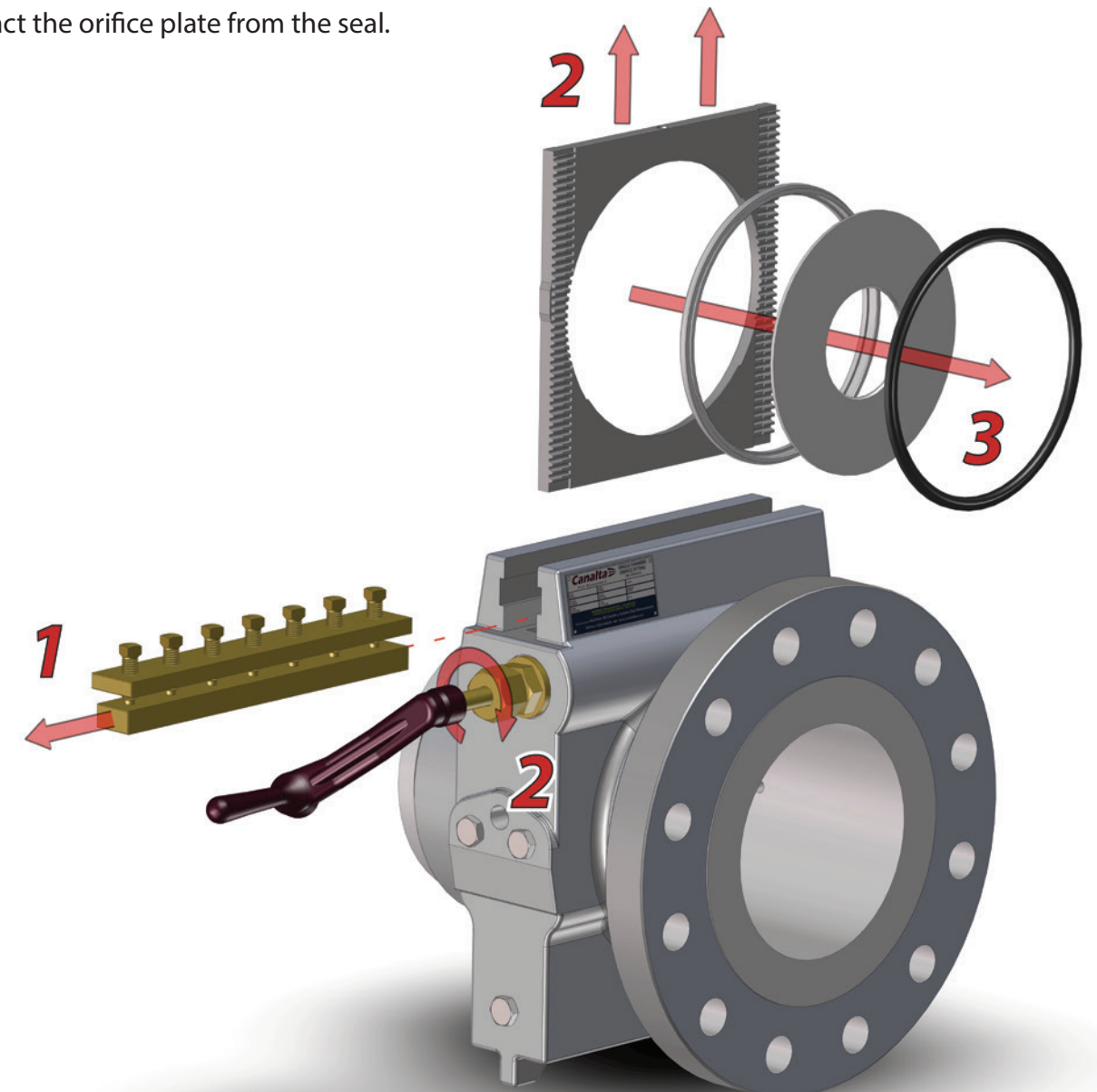

WARNING: The unit may be under extreme high pressure. Failure to depressurize the line before attempting to remove the seal bar may result in bodily harm or death. Follow all instructions carefully.

GENERAL OPERATING NOTES:

- It is the responsibility of the end user to ensure all operating staff are competent and properly trained in the operation of this and all other pressurized equipment.
- It is the responsibility of the end user to assess the expected surface temperature of the unit while in service, and to take the necessary precautions to avoid operator injury.
- It is the responsibility of the end user to account for all vented process fluids, and to develop the necessary procedures to avoid operator injury and environmental damage.

OPERATIONS & MAINTENANCE

2" - 6" SINGLE CHAMBER MODELS

TO REPLACE THE ORIFICE PLATE

- A. Reinstall the orifice plate into the seal.
- B. Install the seal assembly into the plate carrier, ensuring that the orifice plate bevel faces downstream.
- C. Check that the seal bar O-ring or gasket is clean and in position.
- D. Replace the plate carrier and seal bar unit while ensuring that the index hole is placed over the seal bar alignment pin.
- E. Slide the clamping bar back into place and tighten the clamping bar screws.
- F. Check that the meter tap and drain plugs are properly tightened.
- G. Repressurize and return the line to service.

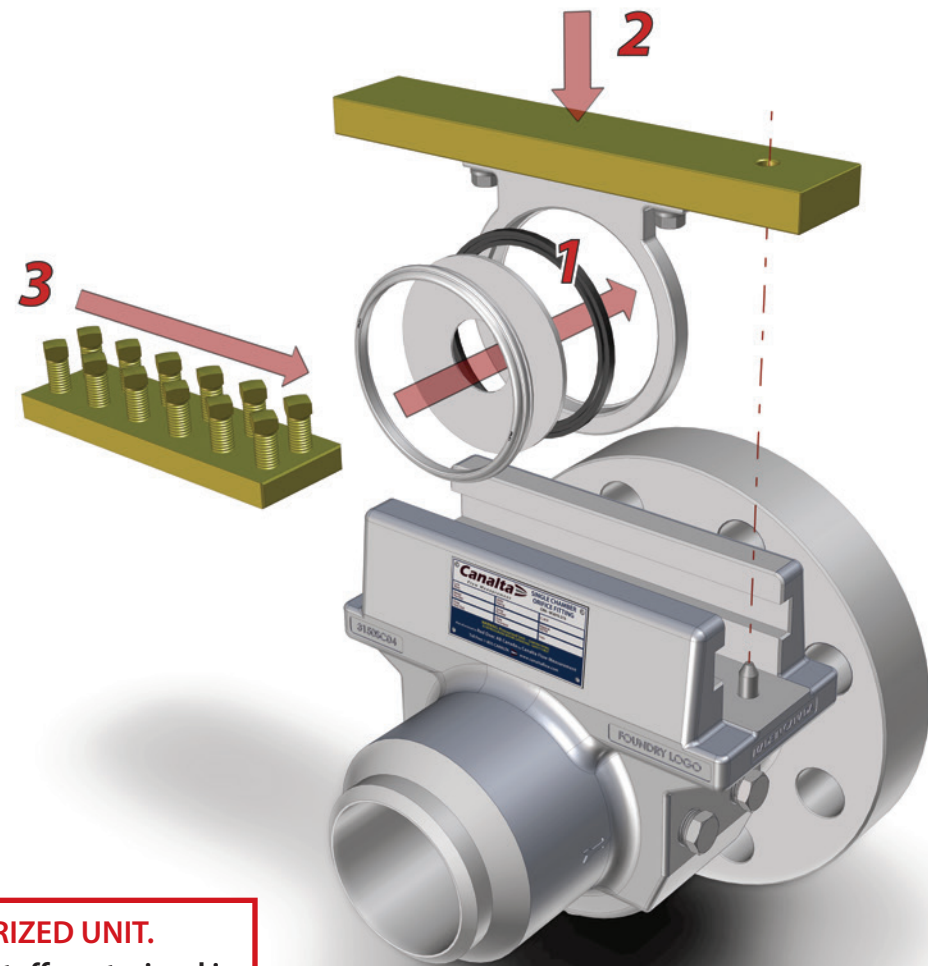

WARNING: PRESSURIZED UNIT.
Ensure all operating staff are trained in the safe operation of this and all other pressurized equipment.

8" - 16" SINGLE CHAMBER MODELS

TO REPLACE THE ORIFICE PLATE

- A. Reinstall the orifice plate into the seal.
- B. Install the seal assembly into the plate carrier, ensuring that the orifice plate bevel faces downstream.
- C. Insert the plate carrier assembly into the fitting and lower it using the plate carrier pinion gear.
- D. Replace the seal bar and clamping bar.
- E. Tighten the clamping bar screws.
- F. Check that the meter tap and drain plugs are properly tightened.
- G. Repressurize and return the line to service.

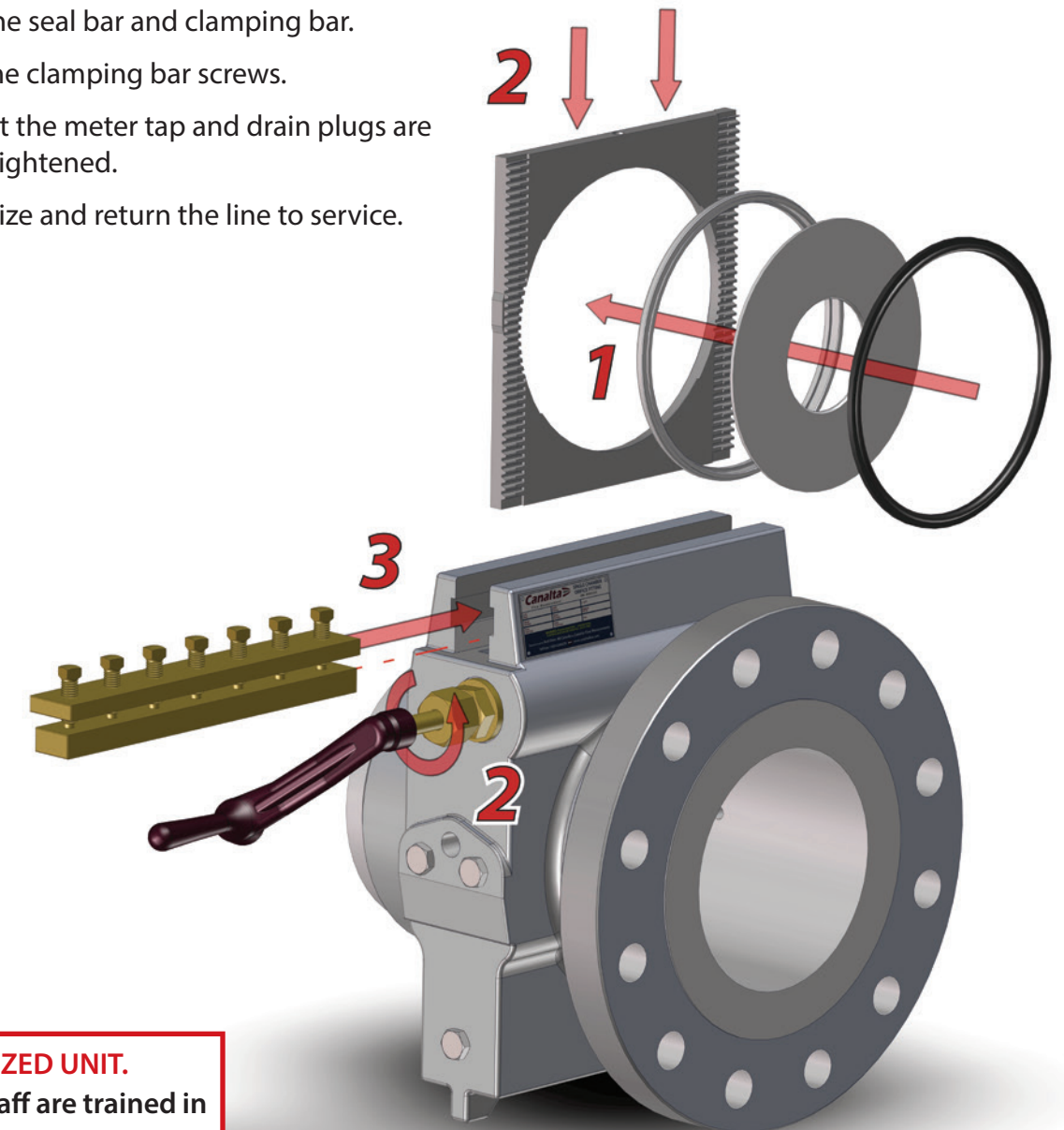

WARNING: PRESSURIZED UNIT.
Ensure all operating staff are trained in the safe operation of this and all other pressurized equipment.

OPERATIONS & MAINTENANCE

INSTALLATION RECOMMENDATIONS

The Single Chamber Orifice Fitting is typically installed in conjunction with upstream and downstream meter run sections (tubes). This is essential to meet the recommendations of both AGA Report 3 and ISO 5167. To obtain the best measurement results, follow the recommended piping configurations and installation requirements of either of these two standards, as well as the recommendations below.

- Always ensure that operating staff are competent and properly trained to operate this and all other pressurized equipment.
- Ensure the system is designed to send clean fluids to the orifice plate. In some cases, a filter installed upstream of the flow meter and in accordance with the flow profile specifications of the relevant standard may be required.
- Ensure that the system is designed to provide the following (wherever required): protection against excessive pressure; fire suppression; protection from degrading or otherwise unstable fluids; access limitation while under pressure or vacuum.
- Ensure that the piping system is designed to avoid all harmful effects, such as water hammer, vacuum collapse, corrosion and uncontrolled chemical reactions.
- When installing the fitting or meter run, ensure that the flow arrow on the outer surface of the fitting corresponds to the direction of flow in the line.
- Attention to clearances is essential. Consult the attached dimensional drawings and tables for details. Ensure there is operating clearance above the top of the fitting for removal of the plate carrier. For 8" - 16" Single Chamber models, additional clearance at the sides of the fitting is necessary for pinion gear rotation and operating wrench removal.
- When used to measure wet gas, the vertical mount is recommended to prevent dam formation against the orifice plate.
- Instrument tap lines should be installed sloping upwards to the differential pressure measurement instrument. Where this cannot be accomplished, use seal pots to chemically seal the sensing lines eliminate hydrostatic head errors.
- To avoid damage to the orifice plate, ensure that the orifice plate and plate carrier are removed from the fitting prior to pressure testing the system.
- Before inserting the orifice plate and plate carrier into the fitting, always ensure that the lower cavity of the fitting is free of debris. If debris has accumulated, remove the lower drain plugs and rod-clean the lower section.

PRESERVATION & STORAGE

The following measures should be taken to preserve and store all orifice fittings and meter runs that are not currently in service:

- Store in dry conditions, preferably indoors to prevent rust and corrosion;
- Apply rust inhibitor every 3-6 months inside the bore to prevent rust and corrosion;
- Ensure orifice plates and seals are removed from the seal gap.
- The end caps shipped with the meter run or fitting should be left in place during storage.
- Hydrostatic testing is required before entering service if stored for more than 1 year;

MODEL NUMBERING SYSTEM

Each individual Canalta Orifice Fitting is assigned a model number which can be found on the unit's sales and quality control documentation. These model numbers facilitate quick identification of specific features of an orifice fitting, such as pipe schedule, body material and applicable standard. To understand the model number on your Canalta Orifice Fitting, use the legend below.

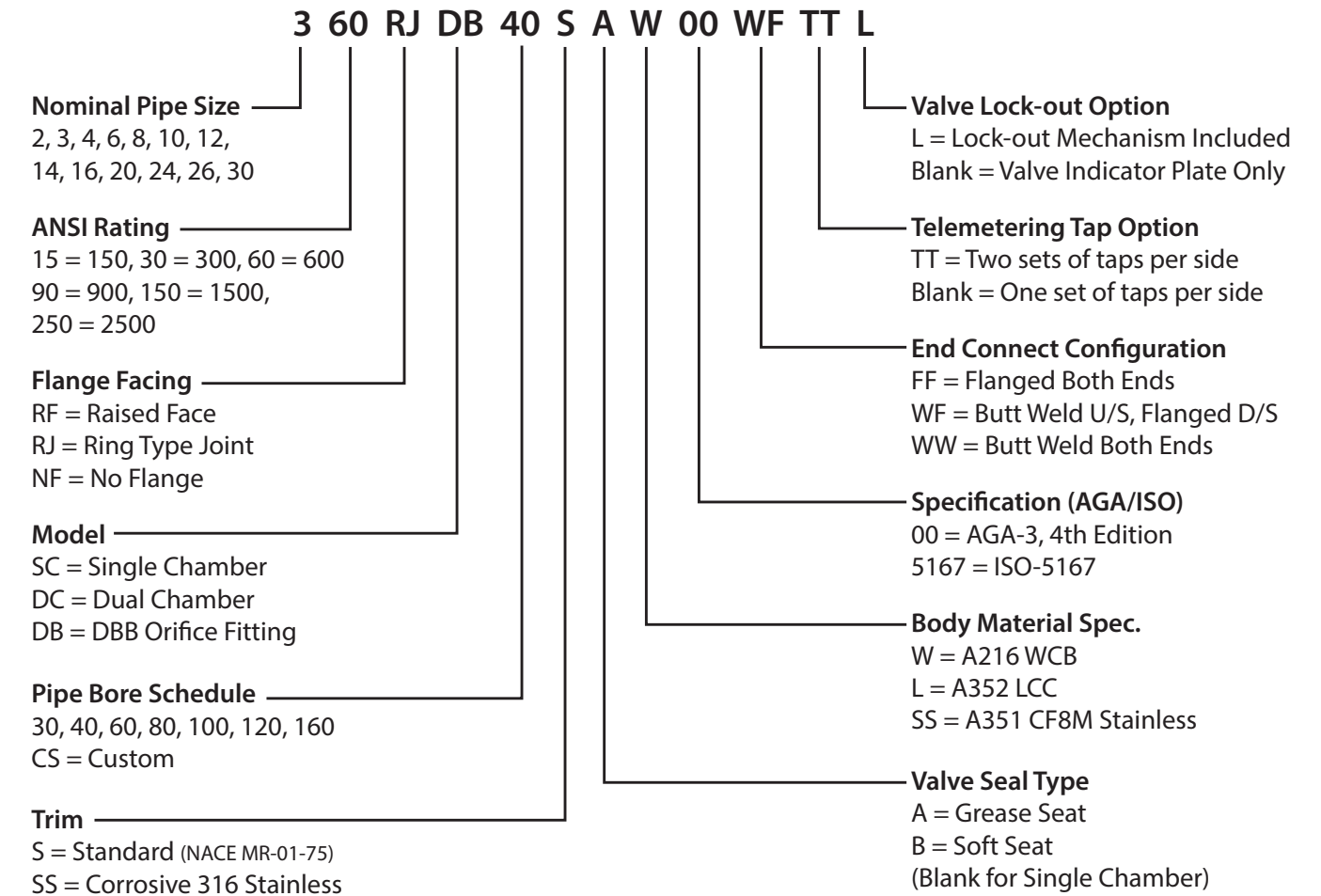

Note: the orifice fitting model number may deviate slightly from this legend in cases where exotic materials or other custom features are included. Please contact us directly for any questions or concerns regarding your Canalta Orifice Fitting.

ADDITIONAL PRODUCT LINES

Canalta also offers these other high quality product lines. Visit us on the web at www.canaltaflow.com to get all the information, or contact us to request print materials.

The Canalta Dual Chamber Orifice Fitting

A high quality, high accuracy orifice fitting manufactured in a wide selection of sizes and materials, the Canalta Dual Chamber Orifice Fitting is designed and constructed to allow for orifice plate inspection or replacement under pressure without interruption in the flow line.

Available as fitting only or with complete meter run, 150# - 2500# ANSI ratings, with carbon or stainless steel internals and a variety of connection configurations.



Parts, Accessories & Repair Kits

Parts and repair kits available for Single and Dual Chamber Orifice Fittings, meter runs and flow conditioning solutions.

Our parts and accessories offerings are interchangeable with the current industry standard orifice fitting brand, making Canalta Orifice Fitting internals suitable for re-builds and re-works of our competitors' product lines at substantial cost savings.

CONTACT INFORMATION

Canalta

Flow Measurement

A Canalta Controls Company

Phone: 403.342.4494 Email: sales@canaltaflow.com

Fax: 403.346.7110 Web: www.canaltaflow.com

Call Us Toll Free: 1-855-CANALTA

6759 65th Avenue
Red Deer, AB T4P 1X5
CANADA

Find a list of our global distribution partners at www.canaltaflow.com/global

The "Canalta Flow Measurement" name and logo are trademarks of Canalta Controls Ltd. All other trademarks are the property of their respective companies.

All information presented here is for information purposes only. Though every effort has been made to ensure their accuracy, the contents of this publication shall not be construed as warranties or guarantees, expressed or implied, regarding the products or services described herein, or their use or applicability. Due to Canalta's commitment to quality and innovation, all product designs, specifications and information material, including the contents of this publication, are subject to change without notice. Responsibility for the proper selection, maintenance and use of any product remains with the customer. SAFETY FIRST.

Copyright, trademark and other forms of proprietary rights protect the contents of this publication.

© 2011-2015 Canalta Controls Ltd. All rights reserved. Unauthorized reproduction in whole or in part is prohibited.